

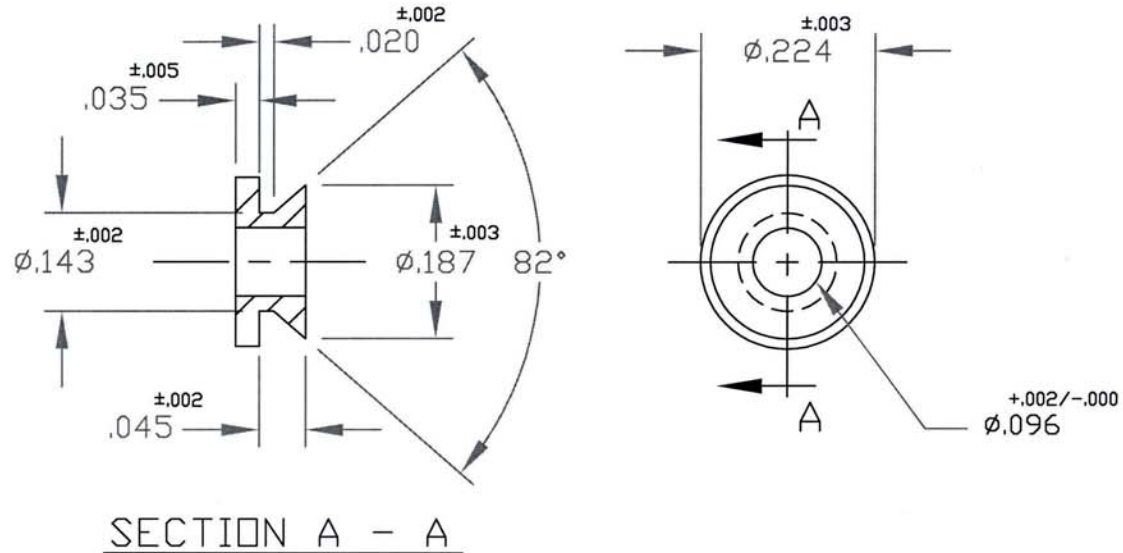

UNCONTROLLED

C5718-F3-3 REV. B

| REVISIONS | | | |
|-----------|-----------------------------|----------|--------|
| SYM | DESCRIPTION | DATE | APPROV |
| B | DELETE 11L17,12L14,ECN 1105 | 10-15-08 | R.C. |



| PART NO. | MATERIAL | FINISH |
|------------------|---|---|
| 5718-F3-3-Z3CT | PER A.I.S.I 1018, 1117, 1214 1215 DR 8620 STEEL. | ZINC PLATE PER ASTM-B-633, TYPE III, SC 2, CLEAR TRIVALENT CHROMATE. |
| 5718-F3-3-SS-PAS | TYPE 303 ST. STEEL | PASSIVATE |
| 5718-F3-3-SS | TYPE 303 ST. STEEL | NATURAL |
| 5718-F3-3-BC | BERYLLIUM COPPER, ALLDY 25, COND. H | |

| | | | | |
|----------------------|--|-----------------------|---|--|
| MAT'L PER NOTE 1. | TOLERANCES ON DIMENSIONS UNLESS OTHERWISE SPECIFIED X* = ±2* .XX = ±.015 X/X = ±1/32 .XXX = ±.010 MACHINE FINISH 125/T | |  DFCI SOLUTIONS INC. 425 UNION BOULEVARD WEST ISLIP, NEW YORK 11795 | |
| HEAT TREAT NONE. | PART NO. | DRN S. Francis | DATE 6-30-05 | TITLE UN-5700 LINE SPACER, 5718-F3-3-Z3CT. |
| FINISH AS NOTED. | | CHK F. Basile | DATE 10-15-08 | SIZE A |
| | | ENG Frank Robinson | DATE 10-15-08 | FSCM NO 72794 |
| | | MFG B. Hildner | DATE 10-15-08 | DWG. NO. C5718-F3-3 |
| | NEXT ASSY | USED ON | DATE 10/15/08 | REV. B |
| | APPLICATION BLOCK | SALES | DATE | SCALE NTS |
| | | | | WT. |
| | | | | SHEET 1 OF 1 |

DATE: 07/01/06 FORM: DRAWING