

UNCONTROLLED

REVISIONS			
SYM	DESCRIPTION	DATE	APPROV
A	INITIAL RELEASE PER ECN 845.	10-9-08	R.C.

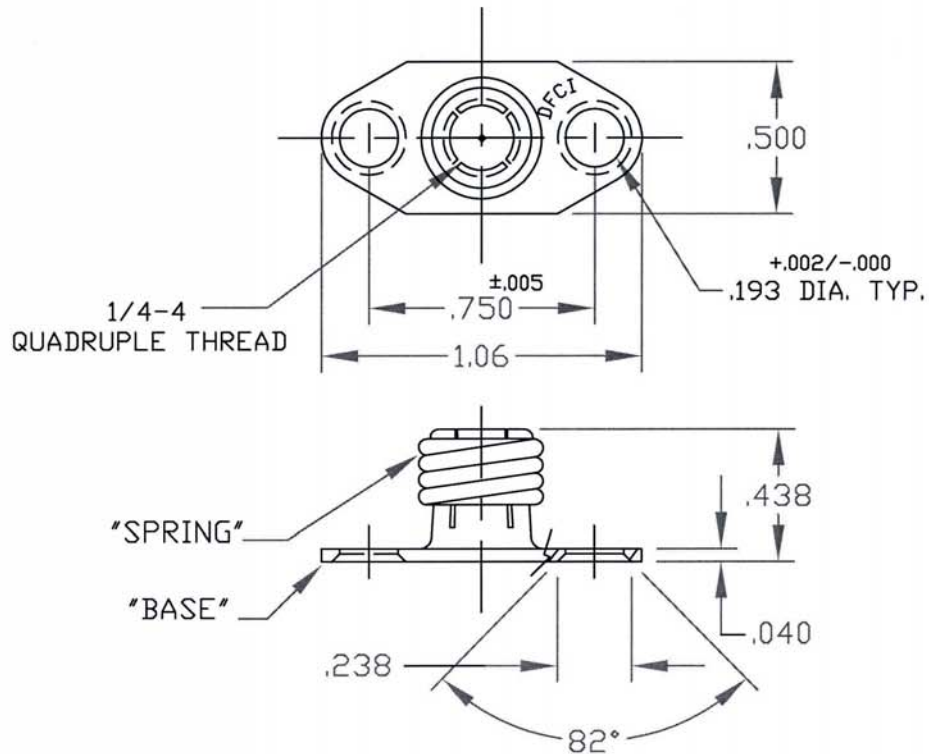

FOR PART NO. REFER TO SHEET 2 of 2.

MAT'L PER NOTE 1.	TOLERANCES ON DIMENSIONS UNLESS OTHERWISE SPECIFIED X° = ±2° .XX = ±.015 X/X = ±1/32 .XXX = ±.010		MACHINE FINISH 125/		DFCI SOLUTIONS INC. 425 UNION BOULEVARD WEST ISLIP, NEW YORK 11795				
	HEAT TREAT NONE.	FINISH PER NOTE 2.	PART NO.	DRN S. Francis DATE 10-9-08		TITLE UN-5700 RECEPTACLE ASSY. 5718-FA4-SS.			
THE FASTENER PARTS SHOWN IN THIS PRINT ARE PROPRIETARY ARTICLES TO WHICH DFCI SOLUTIONS INC. RETAINS THE EXCLUSIVE RIGHTS OF MANUFACTURE, USE AND SALE. THE PRINT OR DRAWING IS SUBMITTED IN CONFIDENCE AND DOES NOT CONVEY A LICENSE OR PERMISSION TO MANUFACTURE THE FASTENER OR FASTENER PARTS.		CHK F. Basil DATE 10-10-08	ENG M. L. L. DATE 10-13-08	MFG B. L. DATE 10-10-08	SALES B. Hildebrand DATE 10-10-08	SIZE A	FSCM NO 72794	DWG. NO. C5718-FA4-SS	REV. A
DATE: 07/01/06 FORM: DRAWING		APPLICATION BLOCK		SCALE NTS		WT.		SHEET 1 OF 2	

UNCONTROLLED

REVISIONS			
SYM	DESCRIPTION	DATE	APPROV
A	INITIAL RELEASE PER ECN 845.	10-9-08	R.C.

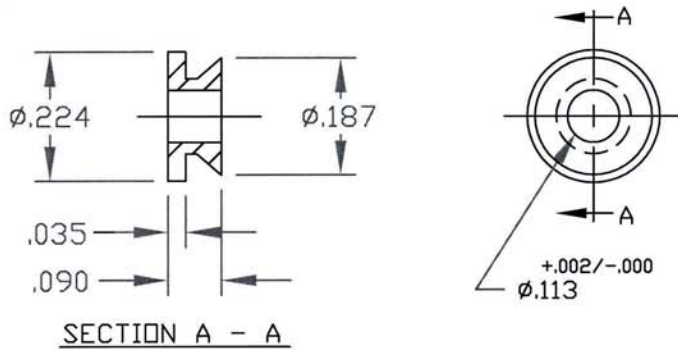

SPACER. (SCALED 2:1)
(SEE NOTE 3)

NOTES:

1. MATERIAL:
BASE, TYPE 303 STAINLESS STEEL.
SPACER, TYPE 303 STAINLESS STEEL.
SPRING: TYPE 316, SPRING TEMPER.
2. FINISH:
BASE, SPRING AND SPACER = NATURAL.
3. TWO (2) SPACERS P/N 5718-F4-3A-SS ARE SUPPLIED W/EACH 5718-FA4-SS RECEPTACLE.
4. THE FLOAT GAP IS .025 IN ALL DIRECTIONS.

PART NO.
5718-FA4-SS

MAT'L PER NOTE 1.		TOLERANCES ON DIMENSIONS UNLESS OTHERWISE SPECIFIED X° = ±2° .XX = ± .015 X/X = ±1/32 .XXX = ± .010 MACHINE FINISH 125/		DFCI SOLUTIONS INC. 425 UNION BOULEVARD WEST ISLIP, NEW YORK 11795		
HEAT TREAT NONE.		PART NO.	DRN S. FRANCIS DATE 10-9-08	UN-5700 RECEPTACLE ASSY. 5718-FA4-SS.		
FINISH PER NOTE 2.		CHK F. Basil DATE 10-10-08	ENG [Signature] DATE 10-13-08			
<small>THE FASTENER PARTS SHOWN IN THIS PRINT ARE PROPRIETARY ARTICLES TO WHICH DFCI SOLUTIONS INC. RETAINS THE EXCLUSIVE RIGHTS OF MANUFACTURE, USE AND SALE. THE PRINT OR DRAWING IS SUBMITTED IN CONFIDENCE AND DOES NOT CONVEY A LICENSE OR PERMISSION TO MANUFACTURE THE FASTENER OR FASTENER PARTS.</small> <small>© COPYRIGHT 2003, DFCI SOLUTIONS INC. ALL RIGHTS RESERVED.</small>		NEXT ASSY	USED ON	SIZE A	FSCM NO 72794	
		APPLICATION BLOCK	SALES	DATE 10-10-08	DWG. NO. C5718-FA4-SS	REV. A
DATE: 07/01/06 FORM: DRAWING				SCALE NTS	WT.	SHEET 2 OF 2