

UNCONTROLLED

REVISIONS			
SYS	DESCRIPTION	DATE	APPROV
B	PER ECN 1168 & 1234	10/24/13	

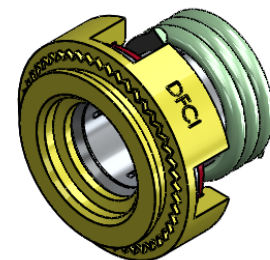
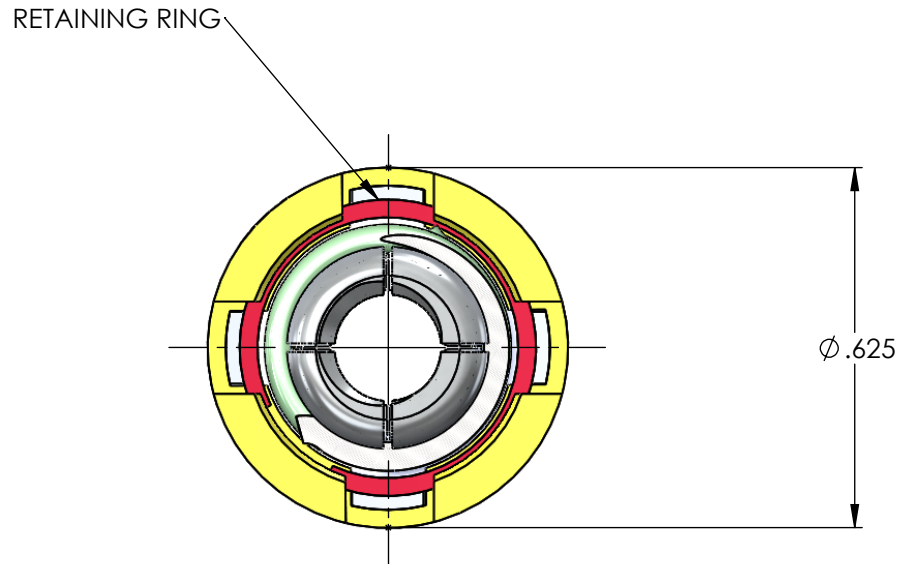
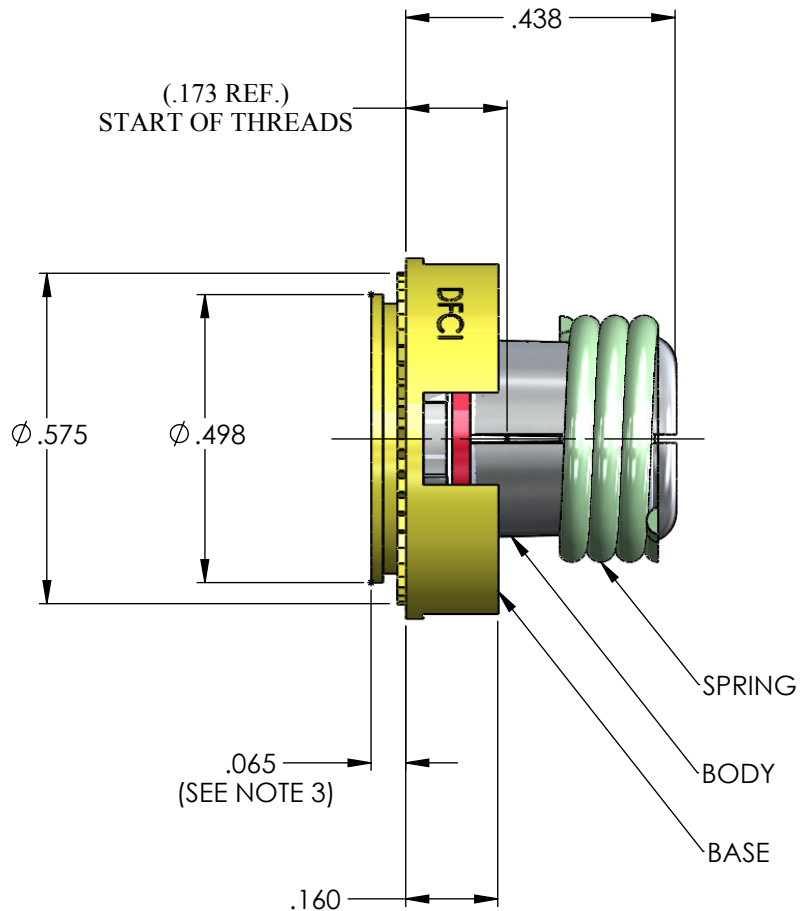

MATERIAL:	SEE NOTE 1
HEAT TREAT:	BASE- ROCKWELL C40-45
FINISH:	SEE NOTE 2
<small>THE FASTENER PARTS SHOWN IN THIS PRINT ARE PROPRIETARY ARTICLES TO WHICH DFCI SOLUTIONS INC., RETAINS THE EXCLUSIVE RIGHTS OF MANUFACTURE, USE AND SALE. THE PRINT OR DRAWING IS SUBMITTED IN CONFIDENCE AND DOES NOT CONVEY A LICENSE OR PERMISSION TO MANUFACTURE THE FASTENER OR FASTENER PARTS.</small>	
<small>(C) COPYRIGHT 2009, DFCI SOLUTIONS INC. ALL RIGHTS RESERVED.</small>	

TOLERANCES ON DIMENSIONS UNLESS OTHERWISE SPECIFIED			
<small>X* = ±2°</small>		<small>.XX = ±.015</small>	
<small>X/X = ±1/32</small>		<small>.XXX = ±.010</small>	
<small>MACHINE FINISH = 125/7</small>			
PART NO.	5718-FP4-ACNC	DRN	DATE
		CHK.	DATE
		ENG.	DATE
		MFG.	DATE
		G.C.	DATE
		SALES.	DATE
NEXT ASSY	USED ON		
APPLICATION BLOCK			

DFCI SOLUTIONS INC.
 425 UNION BOULEVARD.
 WEST ISLIP, NEW YORK 11795

TITLE UN-5700 RECEPTACLE ASSEMBLY 5718-FP4-ACNC			
SIZE	FSCM NO.	DWG. NO.	REV.
A	72794	C5718-FP4	B
SCALE: NTS		WEIGHT: .01156 LB.	SHEET 1 OF 2

UNCONTROLLED

REVISIONS			
SYS	DESCRIPTION	DATE	APPROV
B	PER ECN 1168 & 1234	10/24/13	

NOTES:

1. MATERIAL

BASE: 4140 OR C1141 STEEL
 SPRING: MUSIC WIRE
 BODY: 7075-T6 ALUMINUM
 RETAINING RING: C1060 OR MUSIC WIRE

2. FINISH

BASE, SPRING, & RETAINING RING: ZINC PLATE PER ASTM-B-633, TYPE III, SC2 CLEAR TRIVALENT CHROMATE WITH SEALER.

THE ABOVE MENTIONED FINISH WILL BE SUPPLIED AS THE STANDARD FINISH UPON DEPLETION OF EXISTING STOCK WHICH ARE FINISHED AS FOLLOWS:
 CADMIUM PLATE PER QQ-P-416, TYPE II, CLASS 2 YELLOW CHROMATE.

BODY: ANODIZED PER MIL-A-8625 TYPE 1A, CLASS 1.

3. RECEPTACLE ASSEMBLY TO BE INSTALLED INTO AN .065 MINIMUM SUPPORT THICKNESS.

4. FLOAT .015 IN ALL DIRECTIONS.

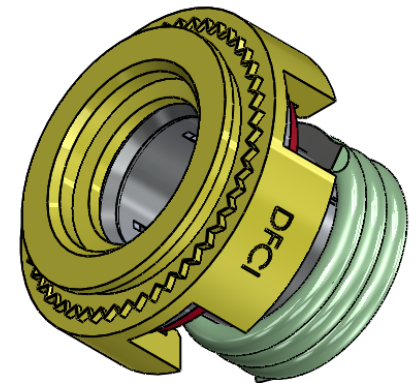

MATERIAL: SEE NOTE 1	TOLERANCES ON DIMENSIONS UNLESS OTHERWISE SPECIFIED X° = ±2° .XX = ±.015 X/X = ±1/32 .XXX = ±.010 MACHINE FINISH = .125				 DFCI SOLUTIONS INC. 425 UNION BOULEVARD. WEST ISLIP, NEW YORK 11795
HEAT TREAT: BASE- ROCKWELL C40-45	PART NO. 5718-FP4-ACNC	DRN <i>Frank Basile</i> DATE 10/24/13	CHK. <i>Frank Basile</i> DATE 10/24/13	ENG. <i>Frank Basile</i> DATE 10/24/13	
FINISH: SEE NOTE 2		MFG. <i>Rashm Lubman</i> DATE 10/24/13	Q.C. <i>Frank Basile</i> DATE 10/24/13	SALES. <i>Frank Basile</i> DATE 10/24/13	TITLE UN-5700 RECEPTACLE ASSEMBLY 5718-FP4-ACNC
<small>THE FASTENER PARTS SHOWN IN THIS PRINT ARE PROPRIETARY ARTICLES TO WHICH DFCI SOLUTIONS INC., RETAINS THE EXCLUSIVE RIGHTS OF MANUFACTURE, USE AND SALE. THE PRINT OR DRAWING IS SUBMITTED IN CONFIDENCE AND DOES NOT CONVEY A LICENSE OR PERMISSION TO MANUFACTURE THE FASTENER OR FASTENER PARTS.</small> <small>(C) COPYRIGHT 2009, DFCI SOLUTIONS INC. ALL RIGHTS RESERVED.</small>	NEXT ASSY	USED ON	APPLICATION BLOCK	SALES.	SIZE A FSCM NO. 72794 DWG. NO. C5718-FP4 REV. B SCALE: NTS WEIGHT: .01156 LB. SHEET 2 OF 2