

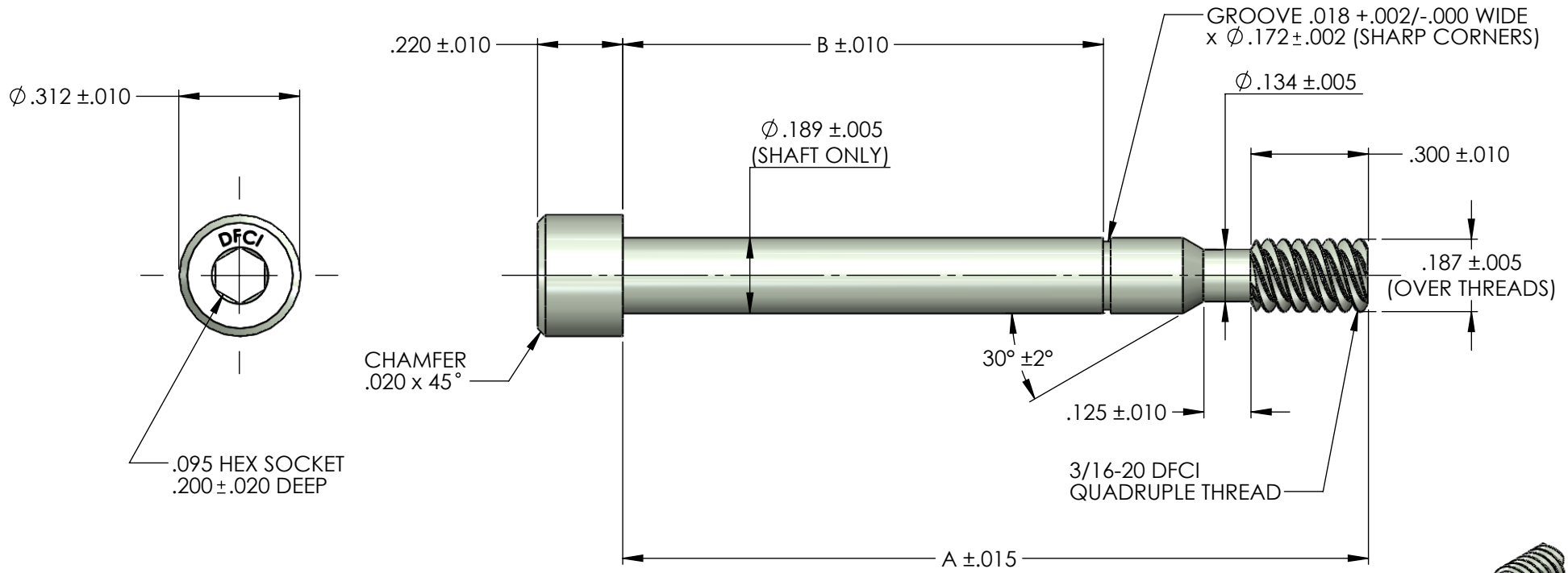

# UNCONTROLLED

REVISIONS			
SYS	DESCRIPTION	DATE	APPROV
A	PER ECN 845 & 1168	11/18/13	

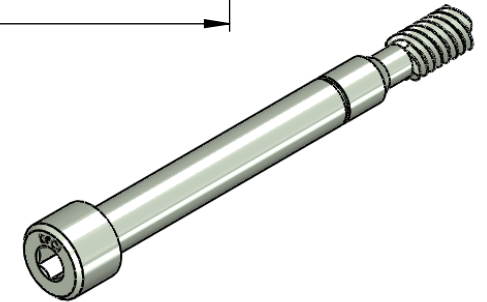

PART NUMBER	A DIMENSION	B DIMENSION
5723-20-515-25260-SS-PAS	5.520	3.920
5723-20-716-25260-SS-PAS	7.528	5.928
5723-20-599-25260-SS-PAS	6.363	4.790



MATERIAL: TYPE 303 STAINLESS STEEL		TOLERANCES ON DIMENSIONS UNLESS OTHERWISE SPECIFIED X* = ±2° .XX = ±.015 X/X = ±1/32 .XXX = ±.010 MACHINE FINISH = 125/7				 <b>DFCI SOLUTIONS INC.</b> 425 UNION BOULEVARD. WEST ISLIP, NEW YORK 11795	
HEAT TREAT: NONE		PART NO. SEE TABLE	DRN <i>Frank Basile</i> DATE 11/18/13	CHK. <i>Frank Basile</i> DATE 11/18/13	TITLE UN-5700 HEX RECESS STUD 5723-20-***-25260-SS-PAS		
FINISH: PASSIVATED PER AMS 2700 METHOD 1, TYPE 2			ENG. <i>Frank Basile</i> DATE 11/18/13	MFG. <i>Rashid Ibrahim</i> DATE 11/18/13			SIZE <b>A</b> FSCM NO. 72794 DWG. NO. C5723-25260 REV. A
THE FASTENER PARTS SHOWN IN THIS PRINT ARE PROPRIETARY ARTICLES TO WHICH DFCI SOLUTIONS INC., RETAINS THE EXCLUSIVE RIGHTS OF MANUFACTURE, USE AND SALE. THE PRINT OR DRAWING IS SUBMITTED IN CONFIDENCE AND DOES NOT CONVEY A LICENSE OR PERMISSION TO MANUFACTURE THE FASTENER OR FASTENER PARTS. (C) COPYRIGHT 2009, DFCI SOLUTIONS INC. ALL RIGHTS RESERVED.		NEXT ASSY	USED ON	G.C. <i>Frank Basile</i> DATE 11/18/13	SCALE: NTS WEIGHT: SHEET 1 OF 1		