

UNCONTROLLED

C5763-S SHT. 1of2 REV. A

REVISIONS			
SYM	DESCRIPTION	DATE	APPROV
A	NITIAL RELEASE PER ECN 845.	5-22-08	R.C.

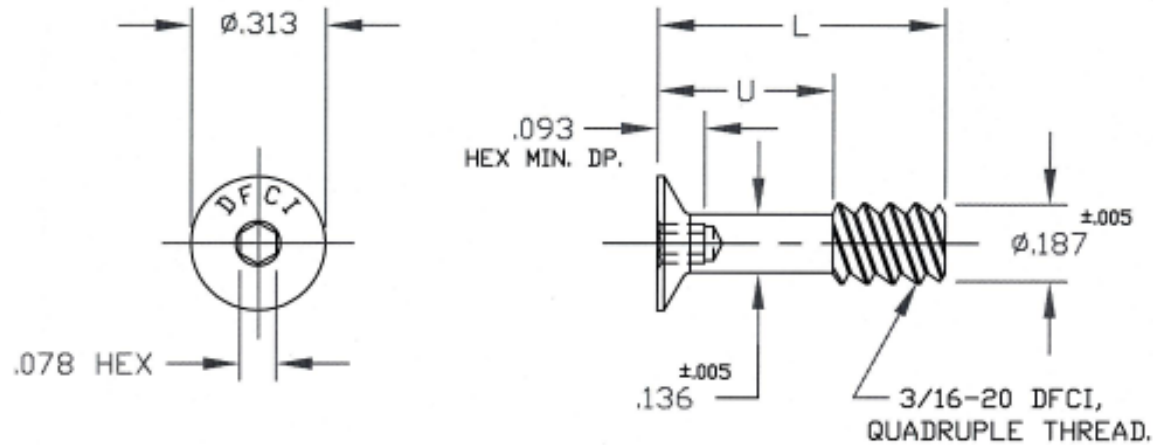

FOR PART NO. REFER TO SHEET 2 of 2.

MATL PER NOTE 1.	TOLERANCES ON DIMENSIONS UNLESS OTHERWISE SPECIFIED X = ±2° .XX = ±.015 X/X = ±1/32 .XXX = ±.010 MACHINE FINISH 125T		DFCI SOLUTIONS INC. 425 UNION BOULEVARD WEST ISLIP, NEW YORK 11795	
HEAT TREAT PER NOTE 2.	PART NO.	DRN S. Franca	DATE 5-22-08	TITLE UN-5700 LINE STUD, 5763-S20-xx-Z2CT.
FINISH ZINC PLATE PER NOTE 3.		CHK F. Basil	DATE 5-22-08	SIZE A
		ENG Sasha Gelbman	DATE 5-22-08	FSCM NO 72794
		MFR B. Basil	DATE 5-22-08	DWG. NO. C5763-S
		QC D. O'Brien	DATE 5-22-08	REV. A
	NEXT ASSY	USED ON	SALES	SCALE NTS
	APPLICATION BLOCK		WT.	SHEET 1 OF 2

DATE: 07/01/06 FORM: DRAWING

UNCONTROLLED

REVISIONS			
SYM	DESCRIPTION	DATE	APPROV
A	NITIAL RELEASE PER ECN 845.	5-22-08	R-C-

NOTES:

- MATERIAL:**
PER A.I.S.I 1018, 1117, 1215, 8620 STEEL
OR TYPE 303 ST. STEEL.
- HEAT TREAT:**
STEEL STUD ONLY: ROCKWELL C30 - 38.
STAINLESS STEEL IS NOT HEAT TREATED.
- FINISH:**
ZINC PLATE PER ASTM-B-633, TYPE III, SC 1,
CLEAR TRIVALENT CHROMATE WITH SEALER.
(RoHS COMPLIANT) FINISH SUFFIX: -Z2CT
THE ABOVE MENTIONED FINISH WILL BE SUPPLIED
AS THE STANDARD FINISH
UPON DEPLETION OF EXISTING STOCK WHICH ARE
FINISHED AS FOLLOW:
CADMIUM PLATE PER QQ-P-416, TYPE I, CLASS 3,
CLEAR CHROMATE. (FINISH SUFFIX: -C2C)
- FOR PART NO. OF STUD MADE FROM TYPE 303 ST.
STEEL, REMOVE SUFFIX -Z2CT FROM P/N AND ADD 'SS'
EXAMPLE 5763-S20-5-SS.
- FOR THE APPLICATION OF ALTERNATIVE FINISHES,
REMOVE SUFFIX -Z2CT FROM THE PART NO.
AND ADD THE REQUIRED FINISH TO THE PART NO. SUFFIX.
*EXAMPLE FOR BLACK ZINC TRIVALENT CHROMATE
5763-S20-5-Z2BT.
- PLEASE VISIT WWW.DFCIS.COM/C5763-S FOR A LIST OF
AVAILABLE FINISHES.

PART NO. (STEEL STUD)	U	L
5763-S20-5-Z2CT	.16	.42
5763-S20-10-Z2CT	.21	.47
5763-S20-15-Z2CT	.26	.52
5763-S20-20-Z2CT	.31	.57
5763-S20-25-Z2CT	.36	.62
5763-S20-30-Z2CT	.41	.67
5763-S20-35-Z2CT	.46	.72
5763-S20-40-Z2CT	.51	.77
5763-S20-45-Z2CT	.56	.82
5763-S20-50-Z2CT	.61	.87

MAT'L PER NOTE 1.	TOLERANCES ON DIMENSIONS UNLESS OTHERWISE SPECIFIED X ^o = ±2 ^o .XX = ±.015 X/X = ±1/32 .XXX = ±.010 MACHINE FINISH 125T		 DFCI SOLUTIONS INC. 425 UNION BOULEVARD WEST ISLIP, NEW YORK 11795	
HEAT TREAT PER NOTE 2	PART NO.	DRN S. F. <i>Rodriguez</i>	DATE 5-22-08	TITLE UN-5700 LINE STUD, 5763-S20-xx-Z2CT.
FINISH ZINC PLATE PER NOTE 3.		CHK <i>F. Basil</i>	DATE 5-22-08	SIZE A
		ENG <i>John K. Wilson</i>	DATE 5-22-08	FSCM NO 72794
		MFG <i>Bill</i>	DATE 5-22-08	DWG. NO. C5763-S
	NEXT ASSY	USED ON	DATE 5-22-08	REV. A
	APPLICATION BLOCK.		SALES	SCALE NTS
			DATE	WT. SHEET 2 OF 2

THE FASTENER PARTS SHOWN IN THIS PRINT ARE PROPRIETARY ARTICLES TO WHICH DFCI SOLUTIONS INC. RETAINS THE EXCLUSIVE RIGHTS OF MANUFACTURE, USE AND SALE. THE PRINT OR DRAWING IS SUBMITTED IN CONFIDENCE AND DOES NOT CONVEY A LICENSE OR PERMISSION TO MANUFACTURE THE FASTENER OR FASTENER PARTS.
 © COPYRIGHT 2008, DFCI SOLUTIONS INC. ALL RIGHTS RESERVED.
 DATE: 07/01/08 FORM: DRAWING