

UNCONTROLLED

REVISIONS			
SYS	DESCRIPTION	DATE	APPROV
A	PER ECN 1168 & 845	04-30-13	

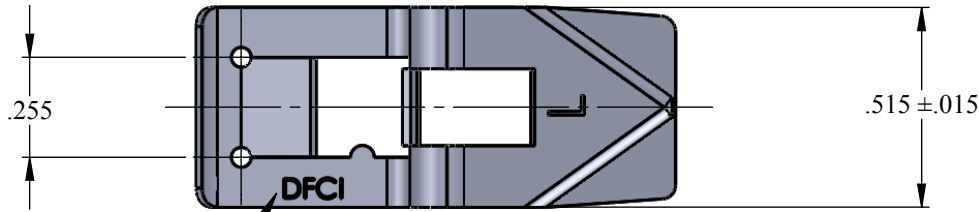

DFCI LOGO OPTIONAL

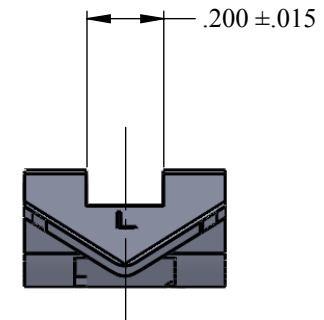
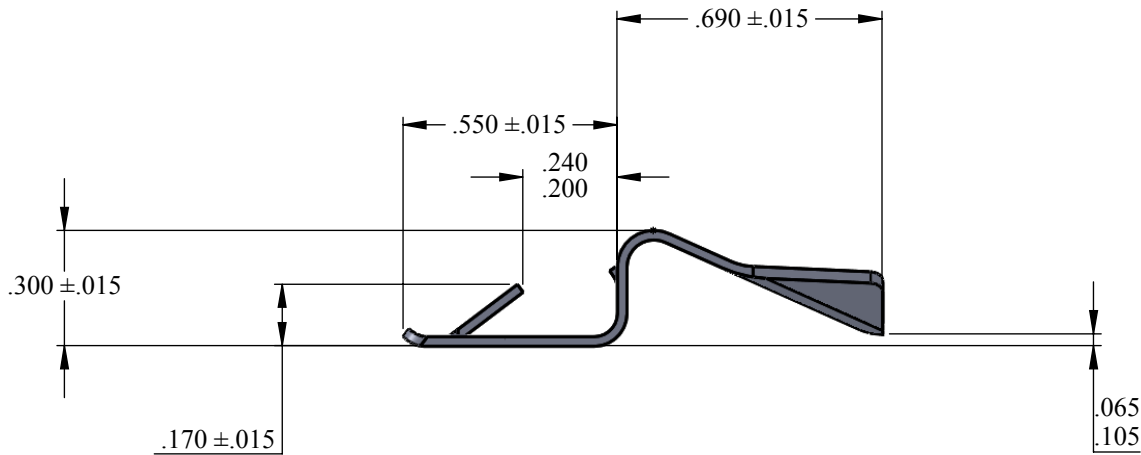
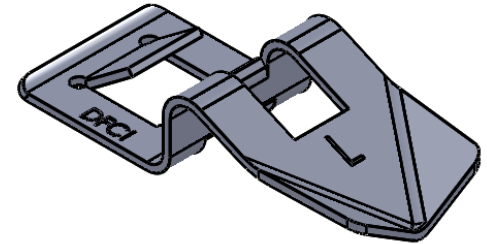

MATERIAL:	410 STAINLESS STEEL
HEAT TREAT:	SPRING TEMPER
FINISH:	NONE
<small>THE FASTENER PARTS SHOWN IN THIS PRINT ARE PROPRIETARY ARTICLES TO WHICH DFCI SOLUTIONS INC., RETAINS THE EXCLUSIVE RIGHTS OF MANUFACTURE, USE AND SALE. THE PRINT OR DRAWING IS SUBMITTED IN CONFIDENCE AND DOES NOT CONVEY A LICENSE OR PERMISSION TO MANUFACTURE THE FASTENER OR FASTENER PARTS.</small>	
<small>(C) COPYRIGHT 2009, DFCI SOLUTIONS INC. ALL RIGHTS RESERVED.</small>	

TOLERANCES ON DIMENSIONS UNLESS OTHERWISE SPECIFIED			
<small>X* = ±2°</small>		<small>.XX = ±.015</small>	
<small>X/X = ±1/32</small>		<small>.XXX = ±.010</small>	
<small>MACHINE FINISH = 125/7</small>			
PART NO.	6137-2L	DRN	Frank Basile
		DATE	04-30-13
		CHK.	Frank Basile
		DATE	04-30-13
		ENG.	Robert Alldread
		DATE	04-30-13
		MFG.	Rashm Lubman
		DATE	04-30-13
		G.C.	Robert Alldread
		DATE	04-30-13
NEXT ASSY	USED ON	SALES.	
APPLICATION BLOCK			



DFCI SOLUTIONS INC.
 425 UNION BOULEVARD.
 WEST ISLIP, NEW YORK 11795

DP-6100 SERIES PAWL
6137-2L

SIZE	FSCM NO.	DWG. NO.	REV.
A	72794	C6137-2L	A

SCALE: NTS

WEIGHT:

SHEET 1 OF 1