

REVISIONS			
SYS	DESCRIPTION	DATE	APPROV
A	INITIAL RELEASE PER ECN 1168 & 845	2-11-2011	

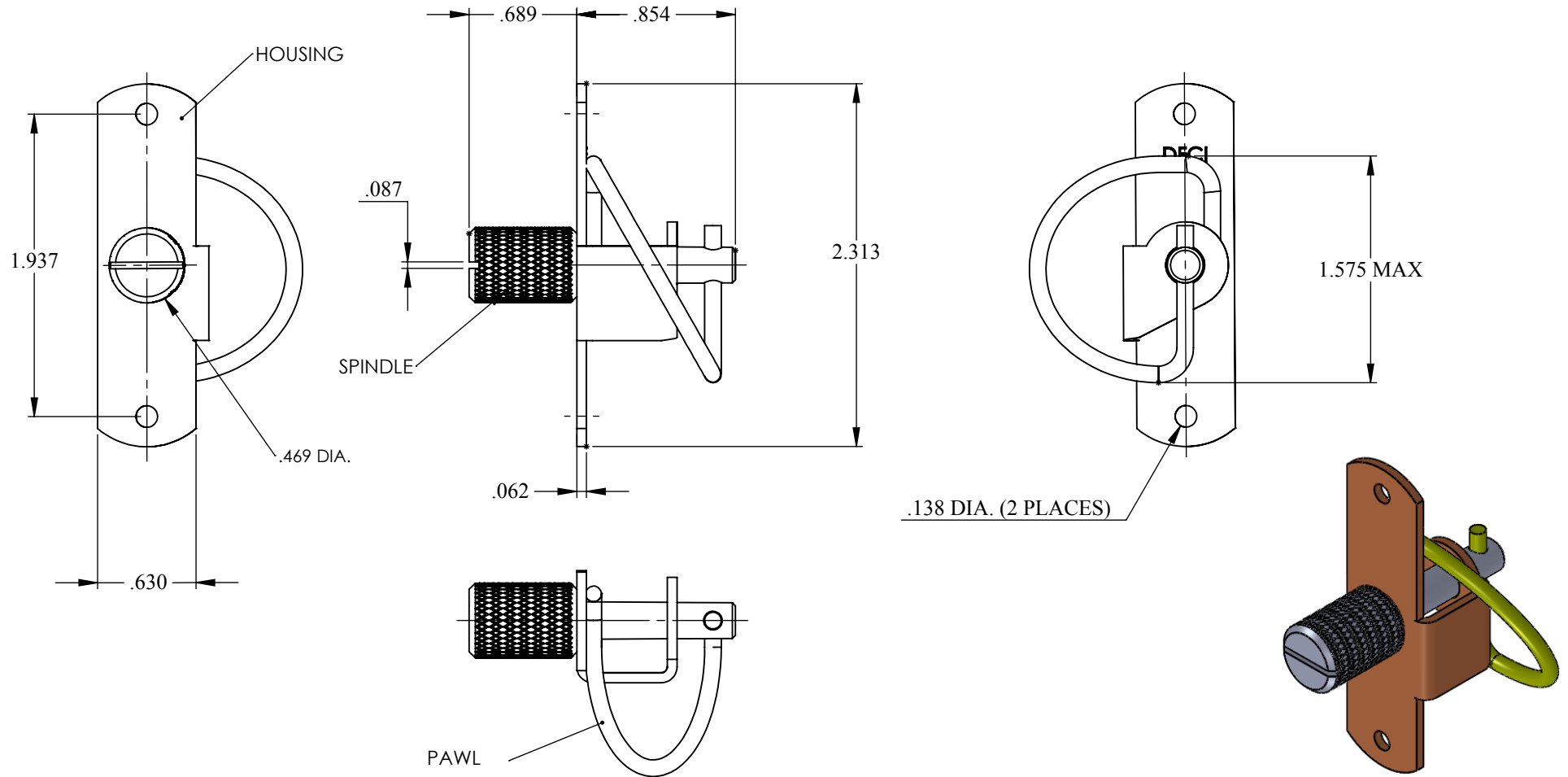

MATERIAL: CARBON STEEL
HEAT TREAT: N/A
FINISH: ZINC PLATE PER ASTM-B-633, TYPE III, SC2, CLEAR TRIVALENT CHROMATE WITH SEALER.
THE FASTENER PARTS SHOWN IN THIS PRINT ARE PROPRIETARY ARTICLES TO WHICH DFCI SOLUTIONS INC., RETAINS THE EXCLUSIVE RIGHTS OF MANUFACTURE, USE AND SALE. THE PRINT OR DRAWING IS SUBMITTED IN CONFIDENCE AND DOES NOT CONVEY A LICENSE OR PERMISSION TO MANUFACTURE THE FASTENER OR FASTENER PARTS. (C) COPYRIGHT 2009, DFCI SOLUTIONS INC. ALL RIGHTS RESERVED.

TOLERANCES ON DIMENSIONS UNLESS OTHERWISE SPECIFIED			
X* = ±1/2°	.XX = ±.015	CONCENTRICITY F.I.M. .005	
X/X = ±1/64	.XXX = ±.010	MACHINE FINISH = .63	
PART NO.	DRN	DATE	
	Frank Basile	2-11-11	
	CHK.	DATE	
	Frank Basile	2-11-11	
	ENG.	DATE	
	Bob Altkrond	2-11-11	
	MFG.	DATE	
	Bill Velazquez	2-11-11	
	G.C.	DATE	
	Bob Altkrond	2-11-11	
NEXT ASSY	USED ON	SALES.	DATE
APPLICATION BLOCK			



**DFCI SOLUTIONS INC.**  
425 UNION BOULEVARD.  
WEST ISLIP, NEW YORK 11795

**6175-K-Z3CT**  
**SELF ADJUSTING SPRING PAWL LATCH**

TITLE	SIZE	FSCM NO.	DWG. NO.	REV.
6175-K-Z3CT SELF ADJUSTING SPRING PAWL LATCH	A	72794	C6175-K	A
SCALE: NTS		WEIGHT:		SHEET 1 OF 1