

UNCONTROLLED

REVISIONS

SYS	DESCRIPTION	DATE	APPROV
C	PER ECN 1168	06/02/10	F.B.

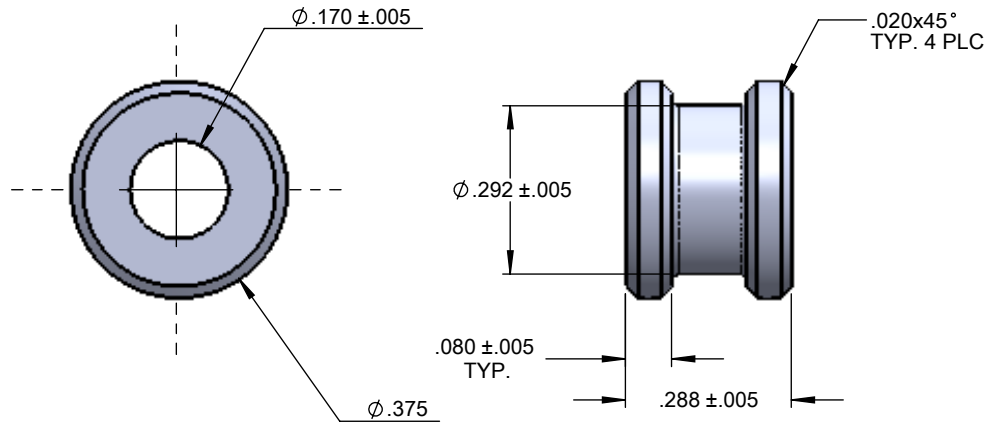

NOTES:

1. FINISH:

ZINC PLATE PER ASTM-B-633, TYPE III, SC2, CLEAR TRIVALENT CHROMATE WITH SEALER. (RoHS COMPLIANT) FINISH SUFFIX: -Z3CT

THE ABOVE MENTIONED FINISH WILL BE SUPPLIED AS THE STANDARD FINISH, UPON DEPLETION OF EXISTING STOCK WHICH ARE FINISHED AS FOLLOW:

ZINC PLATE PER ASTM-B-633, TYPE II, SC 2, YELLOW CHROMATE, FINISH SUFFIX: Z3Y.

2. FOR THE APPLICATION OF ALTERNATIVE FINISHES, REMOVE SUFFIX -Z3CT FROM THE PART NO. & ADD THE REQUIRED FINISH TO THE PART NO. SUFFIX.

EXAMPLE: FOR YELLOW ZINC TRIVALENT CHROMATE FINISH, THE PART NO. IS 8415-03-Z3YT.

3. PLEASE VISIT WWW.DFCIS.COM/C8415-3 FOR A LIST OF AVAILABLE FINISHES.

PART NO.	MATERIAL
8415-03-Z3CT	STEEL (SEE NOTE 3)
8415-03-SS	303 ST. STEEL
8415-03-SS12	304 ST. STEEL

MATERIAL: AS NOTED		TOLERANCES ON DIMENSIONS UNLESS OTHERWISE SPECIFIED X* = ±2° .XX = ±.015 X/X = ±1/32 .XXX = ±.010 MACHINE FINISH = .125 <input checked="" type="checkbox"/>				 DFCI SOLUTIONS INC. 425 UNION BOULEVARD. WEST ISLIP, NEW YORK 11795	
HEAT TREAT: NONE		PART NO.	DRN W. Zhindon	DATE 06/02/10	TITLE SL-8400 SLIDE LATCH ASSY. 8415-03-Z3CT		
FINISH: PER NOTE 1.			CHK. <i>Frank Basile</i>	DATE 06/02/10			SIZE FSCM NO. DWG. NO. REV. A 72794 C8415-3 C
THE FASTENER PARTS SHOWN IN THIS PRINT ARE PROPRIETARY ARTICLES TO WHICH DFCI SOLUTIONS INC. RETAINS THE EXCLUSIVE RIGHTS OF MANUFACTURE, USE AND SALE. THE PRINT OR DRAWING IS SUBMITTED IN CONFIDENCE AND DOES NOT CONVEY A LICENSE OR PERMISSION TO MANUFACTURE THE FASTENER OR FASTENER PARTS. (C) COPYRIGHT 2009, DFCI SOLUTIONS INC. ALL RIGHTS RESERVED.			ENG. <i>Edoardo Aldebrand</i>	DATE 06/15/10	SCALE: NTS WEIGHT: SHEET 1 OF 1		
			MFG. <i>Bill Velazquez</i>	DATE 06/15/10			
		NEXT ASSY	USED ON	Q.C. <i>Edoardo Aldebrand</i>	DATE 06/15/10		
APPLICATION BLOCK		SALES.	DATE				